

THE HEAT LOSSES EXPERIMENTALLY IN THE EVACUATED TUBES SOLAR COLLECTOR SYSTEM IN BAGHDAD-IRAQ CLIMATE

AED IBRAHIM OWAID¹, MOHD TARIQ², HASSAN ISSA³, HUSAM SABEEH⁴ & MOHANNAD ALI⁵

^{1,3,4,5}Solar Research Center, Renewable Energy Directorate, Ministry of Science and Technology, Republic of Iraq

²Department of Mechanical Engineering, SSET, SHIATS-DU, Allahabad, India

ABSTRACT

In this paper has been tested experimentally the thermal losses in solar water heaters with (32) evacuated tubes and tank capacity (263 liters) that have used in the design of a solar energy system for heating a meeting hall of specified area, where the test was in the evening and during the night, heat loss that cause decrease the temperature for hot water in the solar heater storage tank in the evening and during the night as well as it has tested the gain of heat experimentally from solar radiation energy during the day that made rising to the hot water temperature in the solar heater storage tank. where this test was during the winter season and for three consecutive days in February without work the space heating system in environmental conditions in Baghdad in Iraq, in this testing have used data logger with the use of two thermo couples (type k) to measure the temperature of water in the middle of the storage tank solar water heater and the ambient temperature.

KEYWORDS: Evacuated Tube Collector, Hot Water Temperature, Solar Energy, Storage Tank

INTRODUCTION

The evacuated tube solar collectors perform better in comparison to flat plate solar collectors, in particular for high temperature operations. However, previously, it provided no real competition for flat plate solar collectors, because of difficulties in manufacturing and maintenance of the metal-to-glass vacuum seal. One of the most significant developments is the use of double-glass evacuated tubular solar water heaters, which now comprise 65% of 6 million m² / year solar collector market in China. The mechanism of this type of solar water heater is driven by natural circulation of the fluid in the collector and the storage tank. It consists of all-glass vacuum tubes, inserted directly into a storage tank, with water in direct contact with the absorber surface. The limitation of this concept is that it can only be used for a low-pressure system, as the tubes can only withstand a few meters of water head.

Thermal storage is more common than one might think: many households use water storage tanks to provide domestic hot water on command for uses such as washing dishes, washing hands, and showers. These storage water heaters range in size from a few gallons to more than 100 gallons, contain heating elements or burners to heat cold water and maintain its temperature before providing hot water on command to the faucet. Less frequently, thermal storage can be used in space heating systems to store heat for a length of time. Some examples include the storage of solar energy from solar panels for overnight heating and the seasonal storage of heat for use in winter in a district heating system. In either case, thermal storage can be thought of as a “heat battery” because it stores heat energy to be released later.

Man realized that a good use of solar energy is in his benefit, from the prehistoric times. The Greek historian

Xenophon in his 'memorabilia' records some of the teachings of the Greek Philosopher Socrates (470–399BC) regarding the correct orientation of dwellings in order to have houses which were cool in summer and warm in winter. Since prehistory, the sun has dried and preserved man's food. It has also evaporated sea water to yield salt. Since man began to reason, he has recognized the sun as a motive power behind every natural phenomenon. This is why many of the prehistoric tribes considered Sun as 'God'. Many scripts of ancient Egypt say that the Great Pyramid, one of the man's greatest engineering achievements, was built as a stairway to the sun [1].

There are records of solar collectors in the United States dating back to before 1900, [2] comprising a black-painted tank mounted on a roof. In 1896 Clarence Kemp of Baltimore, USA enclosed a tank in a wooden box, thus creating the first 'batch water heater' as they are known today. Although flat-plate collectors for solar water heating were used in Florida and Southern California in the 1920s there was a surge of interest in solar heating in North America after 1960, but especially after the 1973 oil crisis.

MATERIALS AND METHODOLOGY

Evacuated Tube Solar Collector Configuration

The Evacuated tube solar collector in the present study is consists of (32) evacuated tube made of borosilicate glass 3.3,1800mm-long evacuated tube providing the hot water to a (263 liter) horizontal storage tank as shown in figure 1, Hot water in the tube moves by natural convection upward to be replaced by colder water. The hot water produced will be accumulated in the storage tank. The steel mounting structure permits the solar heater to be tilted flexibly to the ground to suit geographical locations. The storage tank is equipped with an electrical heating element to provide hot water in solar unfavorable times.

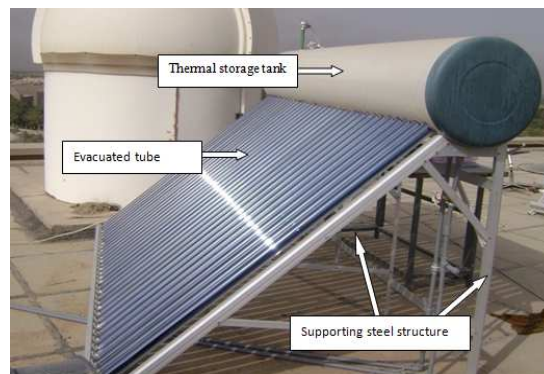

Figure 1: Evacuated –Tube Thermal Solar Collector Array

Solar Heating Elements

Each element (Evacuated tube) is composed of two coaxial borosilicate Glass tubes figure 2 joined at the top and sealed at the bottom which contain a vacuum, the outer of 58mm diameter and (1800mm) length (cover tube) and the inner 47mm diameter and (1720mm) length (absorber tube) that contain 2.6 liters of water. The thickness of inner tube and outer tube is 1.6mm. The inner tube contains the water to be solar heated and its exterior is coated with a suitably dark absorbing material (Nitrite Aluminum) for collecting the incident solar radiation and transmitting it to water. The closed volume between the outer and the inner tube being evacuated works as a thermal insulator preventing heat loss primarily due to convection and conduction. Thus the trapped solar energy absorbed and transmitted to water is prevented from escaping

backward to the environment (green house phenomena). At night or at cold weather the heated water thermally insulated by this vacuum is also then protected from being cooled or frozen. The whole borosilicate-glass tube structure is supported at the bottom on the edge of the outer tube on a horizontal PVC livelihood.

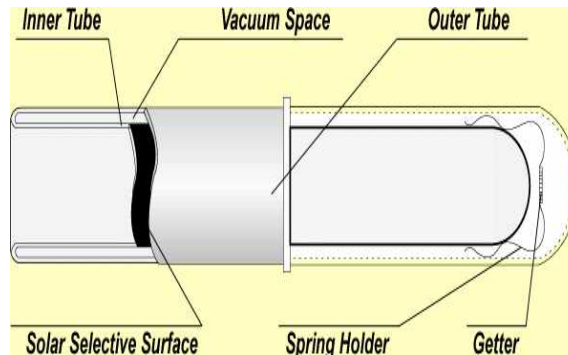

Figure 2: A Schematic Diagram of the Evacuated Tube-Heating Element

According to the manufacturing company (China), transmittance of cover tube is 91% Solar absorptance 93%. Emittance <8% at (80 °C). Pressure of vacuum space: $< 5 \times 10^{-3}$ Pa. Stagnation temperatures (typical) is 200 °C degrees. Impact resistance withstand 25mm diameter hailstone without breaking. Glass strength (pressure tested) is 1 Mpa.

- **Tube Centre Distances:** Distance between centers of tubes is 7.8cm
- **Water Volume in Evacuated Glass-Tubes:** 32 evacuated glass-tubes are containing 32×2.6 liters = 83.2 liter.

Hot Water Storage Tank

Thermally isolated horizontal tank, Outer container made of stainless steel circular cylinder of 270 cm length and 47 cm outer diameter and inner container made of stainless steel circular cylinder of 259 cm length and 36cm diameter, (total volume 263liter) with 55 mm-thick thermal insulation (polyurethane foam) figure 3.

Water in/Out-Let: The cylinder storage tank is equipped with two circular openings at its bottom where two (19mm) diameter steel pipes are fixed to the tank. The two pipes are used for cold water inlet and hot water outlet. Two one-way valves direct the water for either allowing cold water to enter or hot water to leave the tank as required. The total water volume heated by the solar radiation in the system consists of the water contained in the tank and the total amount of water in the heating glass tubes = $263 + (32 \times 2.6) = 346.2$ liter.

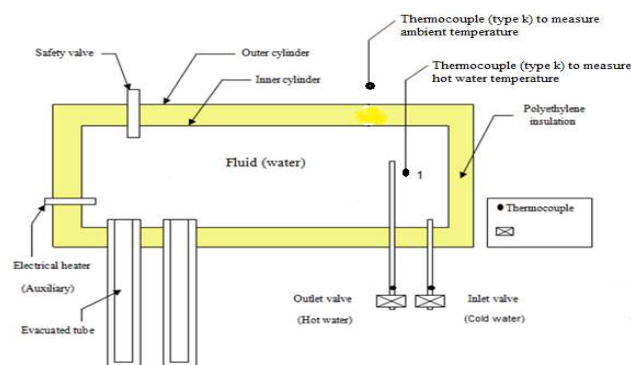

Figure 3: A Cross-Section Schematic Diagram of the Water Storage Tank

Solar Absorbing

The total heating aperture area of the collector comprising the (32) Glass vacuum tubes is $(0.0544\text{m} \times 1.72\text{m}) \times 32 = 2.994176 \approx 3 \text{ m}^2$. The absorber Area is $(1.72 \text{ m} \times 0.0470\text{m} \times 32 \text{ tubes}) = 2.58688 \text{ m}^2$.

Supporting Steel Structure

The steel frame housing the (32) evacuated glass tubes are tilted to the ground by an angle suitable for the geographic location site. The solar collector is situated at a tilt angle (45 degree) and oriented towards south (for northern Hemisphere).

ENERGY BALANCE OF SINGLE EVACUATED TUBE

In a steady state, an energy balance that indicates the distribution of incident solar energy into useful energy gain, thermal losses, and optical losses describes the performance of an Evacuated tube [3]. The solar radiation absorbed by the tube \dot{Q}_{abs} on an hourly basis is equal to the multiply of direct incident solar radiation J_{dir} , aperture area of the absorber A_a and the optical efficiency η_{opt} as shown in Equation (1). The thermal loss from the tube to the surroundings is calculated by considerable detail heat transfer equations. The useful energy output of an evacuated tube \dot{Q}_u is then the difference between the absorbed solar radiation and the thermal loss $\dot{Q}_{\text{thermal-loss}}$ as shown in Equation (2). Which represents an energy rate equation in W, when J_{dir} is expressed in W/m^2 .

$$\dot{Q}_{\text{abs}} = A_a \eta_{\text{opt}} J_{\text{dir}} \quad (1)$$

$$\dot{Q}_u = \dot{Q}_{\text{abs}} - \dot{Q}_{\text{thermal-loss}} \quad (2)$$

The solar radiation is absorbed by glass envelope (outer glass tube) and the absorber tube (inner glass tube) figure 4 can be calculated by Equation (3). The energy loss from glass envelope is the results of convection and radiation from glass to surrounding is calculated by Equation (4).

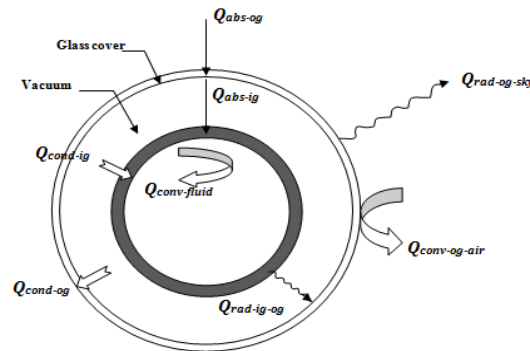

Figure 4: Energy Components in an Evacuated Tube [3]

$$\dot{Q}_{\text{abs}} = \dot{Q}_{\text{abs-og}} + \dot{Q}_{\text{abs-ig}} \quad (3)$$

Where:

\dot{Q}_{abs} is the absorbed solar radiation (W)

$\dot{Q}_{\text{abs-og}}$ is the solar radiation absorbed by outer glass tube (W)

\dot{Q}_{abs_ig} is the solar radiation absorbed by inner glass tube (W)

$$\dot{Q}_{thermal-loss} = \dot{Q}_{rad_og_sky} + \dot{Q}_{conv_og_air} \quad (4)$$

Where:

$\dot{Q}_{rad_og_sky}$ is the radiation heat transfer from outer glass tube (W)

$\dot{Q}_{conv_og_air}$ is the convection heat transfer from outer glass tube (W)

For the outer glass tube surface, the heat gain from solar radiation and inner glass tube by conduction is equal to the heat losses from glass outside surface to ambient by means of convection and radiation[3], such that:

$$\dot{Q}_{abs_og} + \dot{Q}_{cond_og} = \dot{Q}_{conv_og_air} + \dot{Q}_{rad_og_sky} \quad (5)$$

Where \dot{Q}_{cond_og} is the conduction heat transfer through outer glass (W)

For the inner surface of the glass, the income heat is gain from absorber outer surface to inner surface of glass by radiation. It is equal to the heat loss by means of the conduction through glass Equation (6)

$$\dot{Q}_{rad_ig_og} = \dot{Q}_{cond_og} \quad (6)$$

Where $\dot{Q}_{rad_ig_og}$ is the radiation heat transfer through the evacuated enveloping (W).

For the outer surface of the absorber, the heat directly gain from solar is equal to the heat transferred to glass envelope by means of radiation and to the absorber by conduction, Equation (7). The heat conducted to absorber is equal to the heat transfer by convection from absorber to heat transfer fluid Equation (8).

$$\dot{Q}_{abs_ig} = \dot{Q}_{rad_ig_og} + \dot{Q}_{cond_ig} \quad (7)$$

$$\dot{Q}_{cond_ig} = \dot{Q}_{conv_fluid} \quad (8)$$

Where:

\dot{Q}_{conv_fluid} is the convection heat transfer to the fluid (W).

Theoretical Calculation of the Thermal Losses from the Tube

Heat is lost from the outside of the outer glass tube by both radiation and convection [4], but from the absorber inner glass tube to the outer glass tube only by radiation heat transfers figure 5, as the heat lost by both convection and conduction are eliminated by vacuum (about 5×10^{-3} Pa). There is a small amount of conduction from the glass tubes walls through the structure that supports them but this effect has been assumed to be neglected. The heat lost by the tube is given by:

$$\dot{Q}_{loss-tube} = U_L A_{ig} (T_{ig} - T_a) \quad (9)$$

Where:

U_L is overall heat loss coefficient of the tube (W/m².K).

A_{ig} is area of the inner glass tube(m²).

T_{ig} is temperature of the inner glass tube (K).

T_a is the ambient temperature (K).

The heat loss coefficient L is calculated from thermal resistance between the absorber tube and the outer glass tube [4] and between the outer glass tube and the surrounding such that:

$$U_L = \left[\left(\frac{1}{h_{rad,og} + h_{wp}} \right) + \frac{1}{h_{rad,ig}} \right]^{-1} \quad (10)$$

Where:

$h_{rad,og}$ is the radiation heat transfer coefficient of the outer glass tube.

h_{wp} is the adjusted convection heat transfer coefficient of the outer glass tube.

$h_{rad,ig}$ is the radiation heat transfer coefficient of the inner glass tube.

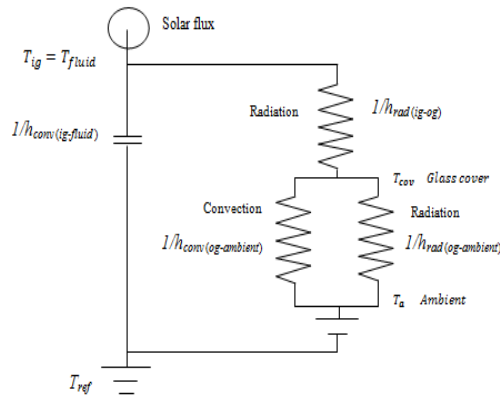

Figure 5: Thermal Circuit Analog of Evacuated Tube [3]

Radiation from the Outer Glass Tube

The radiate loss the outer glass tube surface accounts for radiation exchange with the sky [4] at temperature (T_s). For simplicity, it is referenced to the ambient air temperature (T_a) so that the radiation heat transfer coefficient from the outer glass tube surface can be written in Equation (11).

$$h_{rad,og} = \epsilon_{og} \sigma \times \frac{(T_{og}^4 - T_s^4)}{(T_{og} - T_a)} \quad (11)$$

Where:

ϵ_{og} is the emissivity of the outer glass.

σ is the Stefan –Boltzmann Constant (5.6697×10^{-8}) W/m².K⁴

T_{og} is the temperature of the outer glass tube, K

T_a is the ambient temperature, K

T_s is the equivalent sky temperature as a function of the ambient air temperature, K.

Relates sky temperature to the local air temperature [5] in the simple relationship Equation (12)

$$T_{sky} = 0.0552 T_a^{1.5} \quad (12)$$

The actual radiating surface of each outer glass tube is equal to its surface area, but in fact, much of the view of each outer glass tube is the neighboring outer glass tube or the building structure behind the outer glass tube. Heat radiated only to the front. Therefore the area of the radiation of ($h_{rad,og}$). Equation (11) is assumed to be the product of the outer glass tube diameter and the length ($D_{og} L$) [6].

Outer Glass Tube Convection

The adjusted convection heat transfer coefficient (h_{wp}) of the outer glass tube surface is approximated by heat transfer coefficient around the outer glass tube. Expression for h_w have been determined from data illustrated by Holman [7] for single tube, namely. For the case of natural convection heat transfer Equation (13) is used.

$$h_w = 5.7 + 3.8 v_w \quad (13)$$

Where:

h_w is convection heat transfer coefficient around the outer glass tube

v_w is the wind speed (m/s).

The value of h_w represents the loss per unit area of the outer glass tube surface. For consistency, all losses are referenced to the net collector area.

(A_{ig}). So h_w is multiplied by (A_{og} / A_{ig}) before combining with radiation losses Equation (14). The adjusted wind loss coefficient [6] is:

$$h_{wp} = \frac{A_{og}}{A_{ig}} \times 0.6 \times h_w \quad (14)$$

Radiation from Absorber Glass Tube to the Outer Glass Tube

The radiation heat transfer coefficient between the absorber tube and outer glass tube [8] can be written as:

$$h_{rad,ig} = \varepsilon_{ig-og} \sigma \frac{(T_{ig}^4 - T_{og}^4)}{(T_{ig} - T_{og})} \quad (15)$$

Where ε_{ig} is the effective emissivity between the absorber glass tube (inner tube) and the outer glass tube Equation (16).

$$\varepsilon_{ig-og} = \left\{ \frac{1}{\varepsilon_{ig}} + \frac{A_{ig}}{A_{og}} \left(\frac{1}{\varepsilon_{og}} - 1 \right) \right\}^{-1} \quad (16)$$

The overall heat loss coefficient can be obtained by combining Equations (11), (14), and (15)

The glass temperature T_{og} is found by noting that the heat loss from the absorber tube to the outer glass tube is the same as from the absorber tube to the surrounding Equation (17). Therefore,

$$T_{og} = T_{ig} - \frac{U_L (T_{ig} - T_a)}{h_{rad,ig}} \quad (17)$$

The procedure is to guess an outer glass tube temperature from which $(h_{rad,og})$ and $(h_{rad,ig})$ are calculated. With these heat transfer coefficients and (h_{wp}) , the overall the heat loss coefficient is calculated from Equation (10). These results are then used to calculate T_{gg} from Equation (17). If T_{gg} is closed to the initial guess, no further calculation are necessary. Otherwise, the newly calculated T_{gg} is used and the procedure is repeated.

HEAT LOSS AND GAIN IN THE STORAGE TANK

Relating the Quantity of Heat to the Temperature Change

Specific heat capacities provide a means of mathematically relating the amount of thermal energy gained (or lost) by a sample of any substance to the sample's mass and its resulting temperature change. The relationship between these four quantities is often expressed by the following equation.

$$Q = m \times C_p \times \Delta T \quad (18)$$

Where Q is the quantity of heat transferred to or from the water

The mass of the water (m) = 263 Kg

The specific heat capacity of the water (CP) = 4.2 KJ/(Kg°C)

ΔT is the resulting temperature change of the water. ΔT is equal to (Tfinal - Tinitial) when using the above equation; the Q value can turn out to be either positive or negative. As always, a positive and a negative result from a calculation has physical significance. A positive Q value indicates that the water gained thermal energy from its surroundings; this would correspond to an increase in temperature and a positive ΔT value. A negative Q value indicates that the water released thermal energy to its surroundings; this would correspond to a decrease in temperature and a negative ΔT value.

RESULTS AND DISCUSSIONS

The evaluated tubes solar collector was leaving, which supply energy to the solar space heating system on day 03.02.2012, exposes to environmental conditions without the power supply to the solar space heating system where we have observed from the data that have registered using data logger by using two thermo couple as shown in figure 3. We observed from the figure 6, which represents the relationship between the temperature of the hot water in the middle of the solar collector storage tank, ambient temperature versus local time that the decreasing in hot water temperature because of the heat loss from the time 00:00 am, where the hot water temperature was (57.9°C) and until the time 9:20 am, where the temperature was (54.3°C), that is decreasing about (3.5°C) equivalent to (3866.1KJ) and the rising in the temperature due to the energy gained from solar radiation from the time 9:20 am, where the hot water temperature was (54.3°C) and until the time 4:50 pm, where the temperature was (78.8°C), the difference between them approximately (24.5°C) equivalent to (27062.7KJ) While the decreasing hot water temperature from the time 4:50pm where the temperature was (78.8°C) and until the time 11:50pm where the temperature was (75.2°C), the diminished temperature is about (3.6°C) equivalent to (3976.6KJ), where the completely falling for the hot water temperature for that day about (7.1°C) any equivalent to (7842.7KJ).

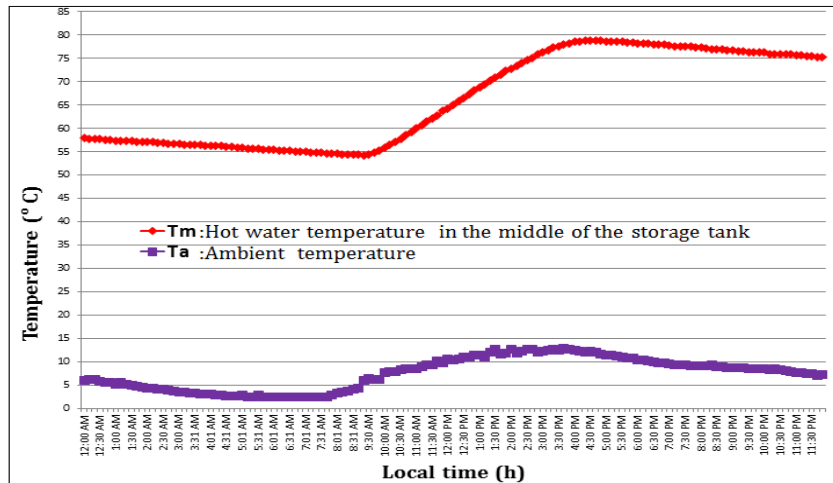

Figure 6: Drop and Rise the Hot Water Temperature in the Solar Collector Storage Tank on 03.02.2012

The next day on 04.02.2012 that means the second day after leaving the solar water heater expose for environmental conditions without supply the energy to the solar space heating system where we have observed from the data that have registered using data logger by using two thermo couple as shown in figure 3, where we observed from the figure 7, which represents the relationship between the temperature of the hot water in the middle of the solar collector storage tank, ambient temperature versus local time that the decreasing hot water temperature because of the heat loss from the time 00:00 am, where water temperature was (75.1°C) and until the time 9:50 am, where the temperature was (69.9°C), that is decreasing about (5.2°C) between different temperature equivalent to (5743.9KJ), and the rising in the temperature due to the energy gained from solar radiation from the time 9:50 am, where the hot water temperature was (69.9°C) and until the time 4:40 pm, where the temperature was (92.3°C), the difference between them approximately (22.4°C) equivalent to (24743KJ) While the decreasing hot water temperature from the time 4:40pm where the temperature was (92.3°C) and until the time 11:50pm where the temperature was (87.8°C), the diminished temperature is about (4.5°C) equivalent to (4970.7KJ), Where the completely falling for the hot water temperature for that day about (9.7°C) equivalent to (10714.6KJ).

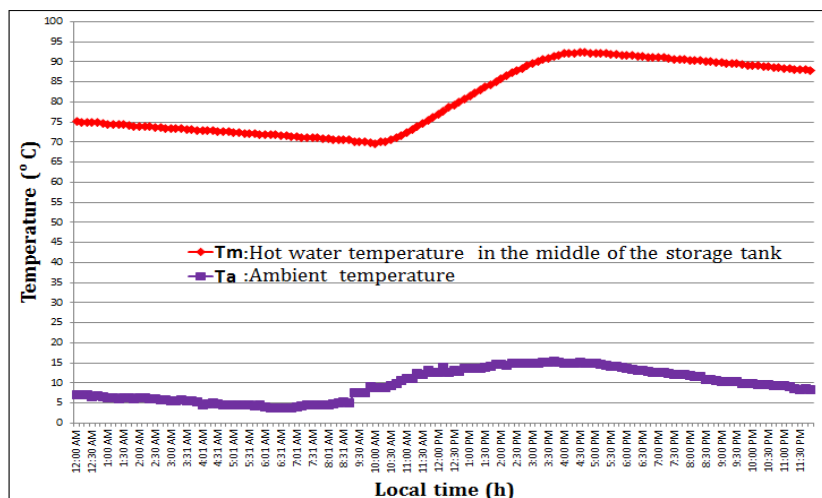

Figure 7: Drop and Rise the Hot Water Temperature in the Solar Collector Storage Tank on 04.02.2012

The next day on 05.02.2012 that means the third day after leaving the solar water heater exposed for environmental conditions without supply the energy to the solar space heating system where we have observed from the data that have registered using data logger by using two thermo couples as shown in figure 3, where we observed from the figure 8, which represents the relationship between the temperature of the hot water in the middle of the solar collector storage tank, ambient temperature versus local time that the decreasing hot water temperature because of the heat loss from the time 00:00 am, where water temperature was (87.7°C) and until the time 9:30 am, where the temperature was (81.4°C), that is decreasing about (6.3°C) between different temperature equivalent to (6959KJ), and the rising in the temperature due to the energy gained from solar radiation from the time 9:30 am, where the hot water temperature was (81.4°C) and until the time 4:50 pm, where the temperature was (100.1°C), the difference between them approximately (18.7°C) equivalent to (20656KJ) While the decreasing hot water temperature from the time 4:50pm where the temperature was (100.1°C) and until the time 11:50pm where the temperature was (95.7°C), the diminished temperature is about (4.4°C) equivalent to (4860KJ). Where the completely falling for the hot water temperature for that day about (10.7°C) equivalent to (11819KJ).

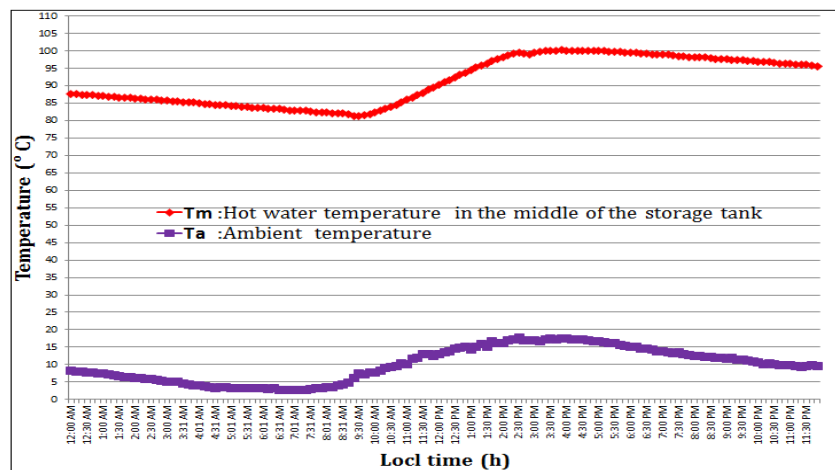

Figure 8: Drop and Rise the Hot Water Temperature in the Solar Collector Storage Tank on 05.02.2012

CONCLUSIONS

In this paper, the thermal losses have been tested, that cause the difference between the consumption energy for heating using solar space heating system using evacuated tubes solar collectors and the gained energy from solar radiation, because of the thermal losses from the evacuated tubes solar collector system, where the main source of heat loss in this system is through the storage tank. That mean the energy losses were in this system in the winter in February for the days (3, 4, 5) where were during the first day (27062.7KJ), for the second day was (24743KJ) and for the third day was (20656KJ).

REFERENCES

1. Anderson B. Solar energy: fundamentals in building design. New York: McGraw-Hill; 1977.
2. a b c Solar Evolution – The History of Solar Energy, John Perlin, California Solar Center.

3. Sophie V. Masson, David H. Archer "A Linear Parabolic Trough Solar Collector Performance Model" Renewable energy Resources and a greener future, Shenzhen, China, Vol.8, 2006.
4. Faizur Rahman "Two Dimensional Mathematical Model of Evacuated Tubular Solar Collector" M.Sc. Thesis the College of Graduate Studies King Fahd University of Petroleum & Minerals Dhahran, Saudi Arabia, February, 1981.
5. Duffie J.A., Beckman W.A. "Solar Engineering of Thermal Processes", 2nd edition, Wiley, New York, 1991.
6. Wilbur P.J." Heat Loss Characteristic of an Evacuated Plate-In-Tube Collector" Report No. A1AA paper 73 NASA center, 1987.
7. Holman J.P. "Heat transfer", McGraw Hill, New York, 1997.
8. Robert, G.T., "Heat Loss Characteristics of an Evacuated plate- In-Tube collector" Solar Energy Vol. 22, PP 137-140, 1979.

